

**PRODUCT CODE:**  
UFLKWA00500-ASH

**LITTER BIN KWA00500 - ASH**

**WASTE BINS**



**DEVICE DATA**

**PROJECTION AND VIEW OF THE DEVICE**

**Compliance with the standard PN-EN:** 1176-1:2017-12

**Device dimensions:** Ø 0.39m

**Device height:** 1.00 m

**Capacity:** 35l

**Foundation depth:** -0.60 m

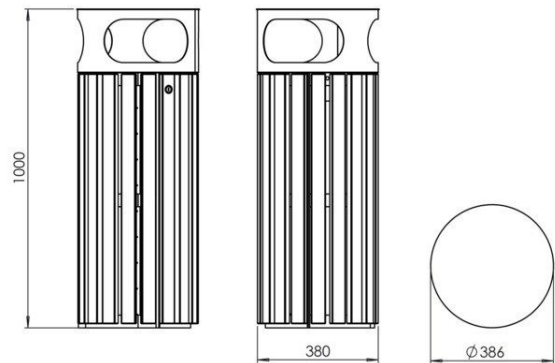

**COMPONENTS**

**Supporting structure** : 1 set

---

**Inner container** : 1 pc.

---

**Side cover** : 1 set

---

**TECHNOLOGY**

**Supporting structure:** galvanized steel, powder coated black

---

**Insert:** bath-galvanized steel, powder coated

---

**Wooden elements:** ash

---

**Mounting to the ground:** pins glued to the foundation

---

Due to continuous improvement of technical solutions, the presented drawings, including colours and dimensions, may differ slightly from currently produced devices.

NOLMO Sp. z o. o. reserves all rights to copyright protection under the Act of 04.02.1994 on copyright and related rights (Journal of Laws No. 28 item 83), in particular Articles 78 and 79 of this Act.